

**TWIN CITY
RACEWAY**

**TRUCK RULES
2010 EDITION**

CLASS SAFETY RULES

- The following rules pertain only to A-Stock, B-Stock, and Late-model classes. Differences in classes will be noted under their class rules.
- **MEDICAL EXAMINATION-** All drivers in classes may be required to take one, as needed, by official request, at the drivers expense.
- **HELMETS-** All classes are mandated to have a full coverage approved auto racing helmet with goggles or full face shield. Helmets must be worn at all times while operating a car on the track or in the pits.
- **FIRE SUITS-** All drivers in classes are required to wear fire retardant apparel in good condition. Minimum long sleeves and long pants.
- **SAFETY BELTS-** All classes are mandated to have a 4 or 5 point safety harness belt, which must be worn at all times when on the track or in the pits. Shoulder harness will be 3" minimum and must be fastened behind the seat at shoulders height or a maximum of 3" below shoulder height. Lap belts must be 3" minimum. All belt and harness anchors must be securely fastened to meet TCR approval. Mandatory one point quick release.
- **FIRE EXTINGUISHERS-** All classes are mandated to have one 2 1/2 pound dry chemical fire extinguisher in their pit area.
- **SEATS-** A-Stock, B-Stock, and Late model must use approved racing type metal seats. Seat must be securely mounted to the roll cage.
- **ROLLCAGES-** A-Stock has a minimum of a four point cage. Construction will be 1 1/4 black pipe schedule 40 minimum or 1 1/2" cage tubing, minimum .095" wall. B-Stock and has a minimum of a six point cage and will be constructed out of 1 1/4 black pipe schedule 40 minimum or 1 1/2" cage tubing, minimum .095" wall.

- **WINDSHIELDS AND DRIVERS DOOR OPENING-** Drivers window must have racing approved removable window net. All classes are required to cover the full opening of the windshield with 1/2" maximum square metal mesh.
- **BRAKES-** All classes are required to have brakes. All four wheel brakes must be operational. No bias adjustment allowed in A-Stock or B- Stock.
- **STARTERS AND BATTERIES-** A-Stock, B-Stock, and Late Model classes are required to have a starter. Batteries must be mounted outside of the driver's compartment and must be securely mounted with steel hold downs.
- **THROTTLE LINKAGE-** All classes are required to have double return springs on carburetor throttle linkage.
- **DRIVE SHAFT -**All classes are required to have their drive shafts painted white in color. Front drive shaft loop is mandatory. Loop is to be a minimum of 1/8" thick by 1 1/2" wide steel mounted no more than 6" to the rear of the front u-joint. If bolted to the floor, the floor must be plated. Plate thickness is 1/8" minimum thickness.
- **FUEL TANKS-** All classes must use an approved racing fuel cell not to exceed 32 US gallons .Tanks must be installed in rear deck space and separated from the driver by a firewall. Tanks must be securely fastened down with metal straps. Tanks must be equipped with a PCV valve or check valve. Filler caps must be located inside of the body of the car.
- **NUMBER SPECIFICATIONS-** All classes must have numbers. Must be a minimum of 18" high with a minimum 2" line width located on both door panels and on the roof in contrasting colors. A minimum of 6" number located on the left front and rear of car in contrasting colors to aid in car lineup is also required. All numbers will be assigned and approved by TCR officials. All cars must meet the approval of the officials as to appearance.

- **RADIATORS AND COOLERS-** All classes must have radiators with overflow bottles. Must be located under the hood and fastened securely. Fan shroud is highly recommended. No oil, transmission or water coolers allowed in driver's compartment. Any oil, transmission or water cooler lines running through driver's compartment must be metal.
- **REFLECTIVE DEVICES-** No reflective devices are allowed in any class. Mirrors will not be allowed in any class.
- **INSPECTIONS-** Any car involved in a major accident must be inspected by a safety official before re-entering competition. A race car may be inspected by officials at anytime. Every registrant of TCR shall at all times conduct him or herself with complete safety and in a prudent manner or a fine may be charged against them by TCR. If there are any questions concerning the class safety rules please contact a director from your class or a track representative.
- **RULE BOOK DISCLAIMER** The rules and/or regulations set forth herein are designed to provide for the orderly conduct of racing events and to establish minimum acceptable requirements for such events. These rules shall govern these events; all participants are deemed to have complied with these rules. **NO EXPRESS OR IMPLIED WARRANTY OF SAFETY SHALL RESULT FROM PUBLICATION OF OR COMPLIANCE WITH THESE RULES AND/OR REGULATIONS.** They are intended as a guide for the conduct of the sport and are in no way a guarantee against injury or death to participant, spectator, or official. Any interpretation or deviation of the rules is left to the discretion of the officials, **THEIR DECISIONS ARE FINAL.**

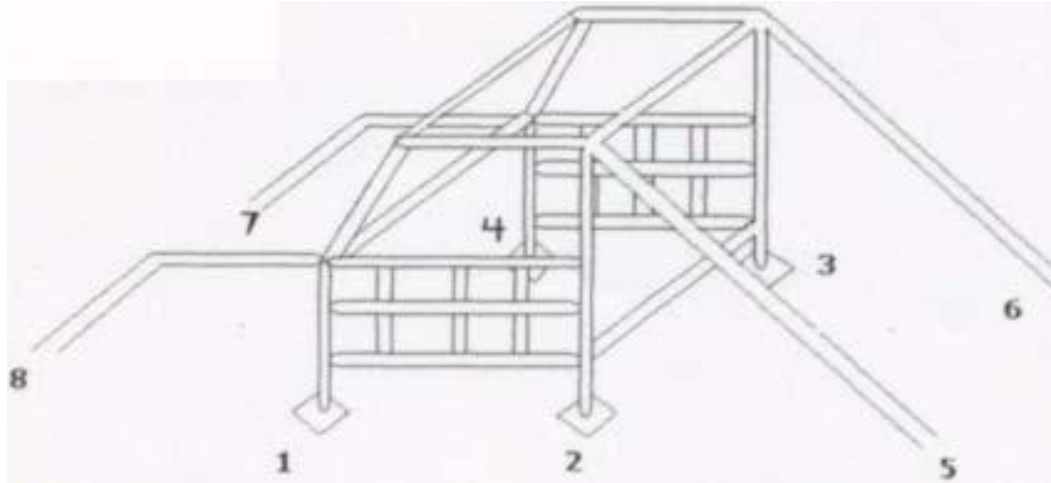

Roll Cage Example:

- *4 point roll cage example: #1 through # 4
- *6 point roll cage example: #1 through # 6
- *front support bars welded for front frame support:
- #7 and #8
- *rear frame supports welded to rear frame: #5 and #6
- *full frame cars, weld posts #1 through #4 to frame rails
- Note for unibodies: - 4 hole plate - 6"x6" pad on all posts min.
- Arrow #1: over plate
- Arrow # 2: floor pan
- Arrow # 3: under plate
- Bumper not to exceed tread width of tires. - Basket type bumpers will be mounted to frame in stock location - Bottom of bumper must be a min. of 12" from the ground. Top of the bumper must be a max. of 24" from the ground.

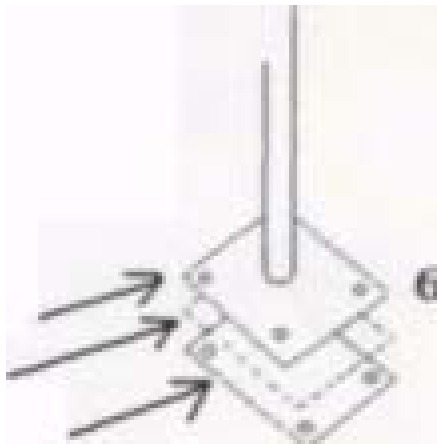

TRUCK CLASS RULES

BODY

- Any American made full size pick up, step side or fleet side, long bed or short bed, years 1950 through 2000.
- Body must be OME factory steel.
- No fiberglass bodies permitted.
- All bodies must be mounted so that the car remains as close to stock appearing as possible.
- Boxed interiors permitted with full floor pan in driver's compartment.
- Homemade nose and tail pieces permitted.
- No mirrors, radios or communication equipment allowed in car at any time.
- Nerf Bar level to be center of axles plus or minus 5" .1" O.D. Max.

SAFETY

- All trucks must have 3' seat belts with shoulder harness and must be attached to roll cage or cab.
- All drivers must wear a complete fire suit. Driver's door must have a window net.

FRAME

- Frame must be stock.

Suspension and Steering

- Must be stock.
- No weight jacks.

BRAKES

- Must be stock or disc.

REAR ENDS

- All rear ends must be locked, welded, mini spool or posi.
- No quick change, floaters, or grand national rear ends.

NUMBER

- Number must be at least 18' high and on both sides of the truck.
- All trucks must have a number.
- 6' number on the left front and the left rear to aid in truck line up.

ROLL CAGE

- All trucks must have a suitable steel roll cage protecting the driver's compartment.
- Side door bars are mandatory, and must extend into the door on driver's side only. Minimum of 3 lateral bars must be used on the left side and 2 on the right side. Right side need not be inside door, but must be a 2 bar minimum.
- Bars must be at least 1 ½ inch in diameter and a minimum of .095 inch wall thickness.
- Roll cages must be welded to frame.

WHEELS

- Wheels must be approved racing type. Safety reinforced on the right front and rear, or A.C.T.A. approved.
- Maximum wheel width 11 inches.
- Bead locks are acceptable.

TIRES

- Not to exceed 12 ½ inches on the ground, measured by footprint on the ground.
- No lug or studded tire allowed.

ENGINE

- All engines have a maximum bore size of .060 over standard. Standard stroke for engine being used.
- Small blocks only. No big blocks.
- Drive train must be in the center line of car.
- Engines may not be crossed from one manufacturer to another....Chevy for Chevy...

BLOCK

- Standard production OEM cast iron V-8 blocks only or V6 blocks.
- Maximum cylinder bore size, 4.185. Ford 400M allowed.
- De-burring block and plugging deck to strengthen block permitted.
- Plug or vent and screen oil drain holes in lifter valley permitted.
- May surface block.
- Lifter bore must be OEM diameter for engine.

CRANK

- Standard production OME cast or steel crank only.
- Must be standard production stroke for engine.
- 351 Max.
- No stroking or de-stroking.
- No lightening or knife edging crank.
- No turning down counter weights or drilling crank pins.
- May balance engine.

RODS

- Stock appearing I-beam OEM design steel rods only.
- No sportsman type rods permitted.
- High performance rod bolts and nuts permitted.
- Polishing rods allowed.
- Pressing or floating pins permitted.

CAM

- Solid lift cam permitted.
- No roller or mushroom cam permitted.

LIFTERS

- Solid lifters permitted.
- No roller or mushroom lifters permitted.
- Lifter retaining tray permitted.
- Lifter must be OEM diameter for engine.

TIMING

- Any chain and gears.
- No gear drives permitted.
- No belt drives permitted.

HEADS

- OEM standard production cast iron heads only.
- Chevy straight plug or angle plug.
- Ford and Chrysler angle plug standard production cast iron heads permitted.
- No Bowtie, World Products W2 or Ford SVO heads allowed.
- May surface heads. (No CC limit)
- Steel valves only. No titanium. Maximum size for all engine...Intake.2.020, Exhaust...1.600.
- .Allow for Ford stock valve size.
- Valve stem diameter... 1 1/32 minimum for all engines.
- Any type guides permitted.
- Any valve springs and keepers permitted.
- Steel retainers required.
- Guide plates and screw in studs permitted.
- Roller rocker arms permitted at any ratio.
- No aftermarket shaft or pedestal mount rocker arms on Chevy.
- If standard production heads came with shaft or pedestal mount rockers, they will be permitted.
- No stud girdles allowed.

HARMONIC BALANCER

- Fluid damper permitted.

WATER PUMP

- Cast or aluminum permitted.

OIL SYSTEM

- Wet sump system only.
- No dry sump system permitted.
- Racing oil pan and or windage tray permitted.
- Remote oil filter and cooler permitted.

FUEL PUMP

- Mechanical pump or electric pumps.

FLYWHEEL

- Steel or aluminum flywheel permitted.

CARBURETOR

- Limited to one four barrel carburetor or two barrel carburetor only.
- No fuel injection, turbo, or blowers permitted.
- Carburetors must have casting lines in venture.
- No BG Silver Claw or Gold Claw permitted.
- No polishing or port of carburetors permitted.
- On standard type Holley choke horn may be removed, but no lower than the breather gasket flange.

INTAKE

- Any single four barrel intake permitted.
- Any size carburetor spacer will be permitted.

DISTRIBUTOR

- OEM factory HEI or OEM factory dual point distributor only.
- After market coil and module will be allowed as long as they are stock appearing and mount in stock location with no modifications.
- Advance kits permitted.
- No ignition booster or amplifier to ignition.
- No dry cell battery pack to ignition.
- Alternator, if used must be wired to the battery. No loop system wiring to the distributor.

STARTER

- All trucks must have a starter in working order.

EXHAUST

- Collector type headers or cast iron manifolds.
- No 180 headers will be permitted.

TRANSMISSION

- OEM standard production 2, 3, or 4 speed transmission only.
- Must have at least one forward and one reverse gear in working order.
- No special production transmission permitted.
- Automatic transmission permitted and coupler allowed.

CLUTCH

- Multi-disc clutch permitted.

FUEL CELL/FUEL

- An approved fuel cell mandatory. (32 gallon maximum)
- Must be securely mounted with two – 1 inch metal straps in the bed of truck, inside metal box, if the floor pan has been removed.
- Gas only. Octane booster is permitted. No alcohol, no nitrous oxide, no nitro methane, or other additives.

WEIGHT?

- **ALL TRUCKS AND DRIVERS ARE REQUIRED TO FOLLOW CLASS SAFETY RULES LISTED IN THE FRONT OF THE RULE BOOK**